



<https://doi.org/10.31217/p.36.1.13>

The influence of SCR on main engine parameters

Filip Rumac¹, Darko Glujić², Dean Bernečić²

¹ Oprić 80, 51415 Lovran, Croatia, e-mail: frumac96@gmail.com

² University of Rijeka, Faculty of Maritime Studies, Studentska 2, 51000 Rijeka, Croatia, e-mail: darko.glujic@pfri.uniri.hr; dean.bernecec@pfri.uniri.hr

ABSTRACT

Air pollution from ships is increasing due to higher global demand of goods, and with them, global emission standards as well. These standards are prescribed by MARPOL Annex VI and the introduction of emission control areas (ECA). Ships built before 1990, do not have to comply with these rules, but ships built after the early 2000, must follow "NO_x Emission Tier I", which allows 17g/kWh NO_x (for the slow speed diesel engines with <130 rpm), and selective catalytic reactors (SCR) are not necessary. Tier III NO_x Emission standard was enforced in 2016 and it requires an 80% reduction in NO_x emission compared to the Tier I, specifically 3.4 g/kWh, which can not be achieved without SCR or without using some other types of fuels. The focus of this paper is to do analysis how the ammonia dosage to SCR affects to the NO_x formation in exhaust gasses on various engine speed (loads), as well as how it affects to some important engine parameters and specific fuel oil consumption (SFOC). The analysis was performed on Kongsberg engine room simulator (ERS), MC 90-V Model, as well as on MATLAB by using mathematical models. All external influences are excluded from the analysis like wind or rough sea. All data on different scenarios has been recorded after prolonged period to avoid inconsistencies. The results are shown graphically, and conclusions are presented.

ARTICLE INFO

Preliminary communication
Received 10 May 2022
Accepted 9 June 2022

Key words:

Selective catalytic reduction
Ammonia
Specific fuel consumption
Main engine scavenging air pressure
Main engine exhaust gas temperature

1 Introduction

The Tier III controls apply only to the specified ships while operating in Emission Control Areas (ECA), established to limit NO_x emissions, outside such areas the Tier II controls apply. In accordance with regulation 13.5.2., certain small ships would not be required to install Tier III engines. A marine diesel engine that is installed on a ship constructed on or after the following dates, and operating in the following ECA, shall comply with the Tier III NO_x standard [1]:

- 1st January 2016 and operating in the North American ECA and the United States Caribbean Sea ECA; or
- 1st January 2021 and operating in the Baltic Sea ECA or the North Sea ECA.

Since all marine diesel engines burning HFO or DO, especially two stroke slow speed diesel engines, can not comply with the Tier III standard only by combustion tun-

ing, or by some other known method, the SCR (and scrubbers) installation on such vessels are necessary.

To provide good operational process of SCR it needs ammonia for chemical reaction. For reasons of safety, the ammonia is normally added to the system in the form of aqueous urea. This decomposes to ammonia and carbon dioxide when it is injected into the vaporiser [3]. It is placed in segregated tanks outside engine room due to safety reasons. By specially designed pipelines and safety control and automation system, it leads to the reactor, which is placed near main engine into the engine room.

The main components of the system are urea tank, evaporator, static mixer, reactor, SCR control, ammonia slip controller and pipeline with sensors and gauges.

SCR plant is installed on exhaust pipeline and has influence on main engine (ME), exhaust back pressure, as well as on exhaust gas flow, temperatures and pressure. Most engines can tolerate 3 kPa (0.03 bar) backpressure with-

out significant power degradation or adverse effects. For each additional 3 kPa of back pressure, exceeding the ratio will degrade performance by 1% [4]. So it is logically to assume that SCR plant has an influence on ME operation which will be investigated in this paper by using Kongsberg Simulation (KS). The main parameters change which will be investigated are; NOx emission, exhaust gas temperature, scavenging air pressure and temperature, specific fuel oil consumption, ammonia slip and optimal value of urea dosage.

2 Ammonia and ammonia reaction in SCR

Two forms of ammonia can be used in SCR systems: pure anhydrous ammonia and aqueous ammonia. Anhydrous ammonia is toxic, hazardous and requires thick-shell, pressurized storage tanks and pipeline due to its high vapor pressure. Aqueous ammonia (NH₃H₂O), is less hazardous and easier to handle. A typical industrial grade ammonia, containing about 27% ammonia and 73% of water (by weight), has nearly atmospheric vapor pressure at normal temperatures and can be safely transported [2].

A number of chemical reactions occur in the ammonia SCR system, as expressed by equations (1) to (5). All of these processes represent reactions which reduce NOx to elemental nitrogen. Equation (2) represents the dominant reaction mechanism. Reactions given by equation (3) through (5) involve nitrogen dioxide reactant. Normally, NO₂ concentrations in most flue gases, including diesel exhaust, are low. In diesel SCR systems NO₂ levels are often intentionally increased to enhance NOx conversion at low temperatures [2].

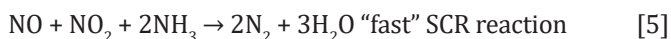
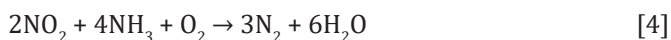
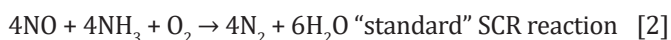

If the NO₂ content is increased to exceed the NO concentration in the feed gas, N₂O formation is also possible [2].

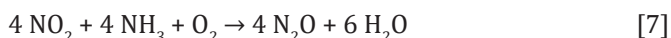
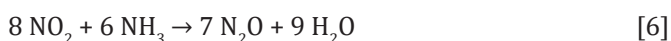

Undesirable processes occurring in SCR systems include competitive, nonselective reactions with oxygen, which is abundant in the system. These reactions can either produce secondary emissions or, at best, unproductively consume ammonia. Partial oxidation of ammonia, given by equations (8) and (9), may produce nitrous oxide (N₂O) or elemental nitrogen. Complete oxidation of ammonia, expressed by equation (10), generates nitric oxide (NO) [2].



Ammonia can also react with NO₂ producing explosive ammonium nitrate (NH₄NO₃), equation (11). This reaction, due to its negative temperature coefficient, occurs at low temperatures, below about 100-200 °C. Ammonium nitrate may deposit in solid or liquid form in the pores of the catalyst, leading to its temporary deactivation [2].



Ammonium nitrate formation can be avoided by making sure that the temperature never falls below 200 °C. The tendency of NH₄NO₃ formation can be minimized by supplying into the gas stream less than the precise amount of NH₃ necessary for the stoichiometric reaction with NOx (1 to 1 mole ratio) [2].

When the flue gas contains sulfur, as is the case with diesel exhaust, SO₂ can be oxidized to SO₃ with the following formation of H₂SO₄ upon reaction with H₂O. These reactions are the same as those occurring in the diesel oxidation catalyst. In another reaction, NH₃ combines with SO₃ to form (NH₄)₂SO₄ and NH₄HSO₄, equation (12) and (13), which deposit on and foul the catalyst, as well as piping and equipment. At low exhaust gas temperature, generally below 250 °C, the fouling by ammonium sulfate may lead to a deactivation of the SCR catalyst [2]. For HFO with 3.5% of Sulphur, a minimum exhaust gas temperature should not go below 325°C [3].



The SCR process requires precise control of the ammonia injection rate. An insufficient injection rate results in unacceptably low NOx conversions. An injection rate which is too high results in release of undesirable ammonia to the atmosphere (ammonia slip). These ammonia slip increase with increasing NH₃/NOx ratio (also referred to as alpha ratio). According to the dominant SCR reaction, equation (2), the stoichiometric NH₃/NOx ratio in the SCR system is about 1. Ratios higher than 1 significantly increase ammonia slip. The ammonia slip decreases with increasing temperature, while the NOx conversion in an SCR catalyst may either increase or decrease with temperature, depending on the particular temperature range and catalyst system [2].

Alpha ratios between 0.9 and 1 can be used to minimize ammonia slip while still providing satisfactory NOx conversions. However, in applications with very demanding NOx performance targets, the SCR system must be operated with alpha ratios of ≥ 1. In such cases, ammonia slip can be controlled using a guard catalyst (ammonia oxidation catalyst) positioned downstream of the SCR catalyst [2].

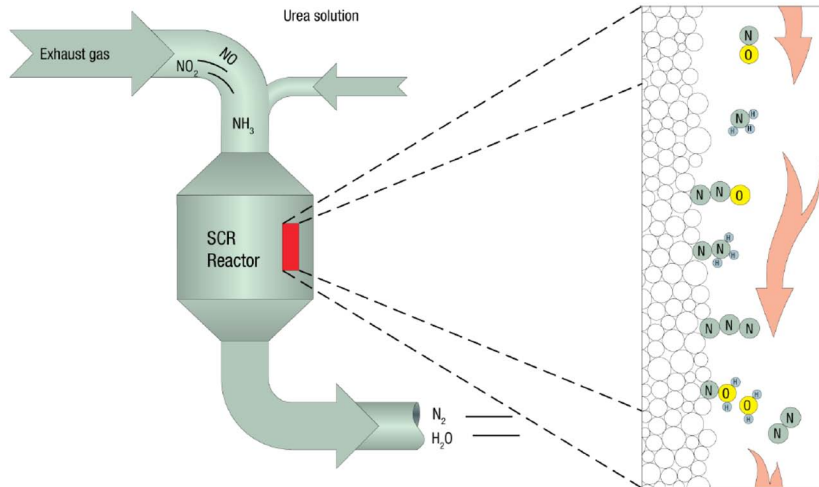

Figure 1 SCR principle [3]

SCR can be used as a standalone system and its efficiency in removing NOx is around 90% [3]. This technology is not new and was first patented in United States by the Engelhard Corporation in 1957, and first SCR was installed by the IHI Corporation in 1978, but for marine operation technology needed to be perfected for safety and reliability concerns [3]. Also, at the time IMO did not require such a high standard for NOx reduction.

3 SCR systems

To meet the Tier III NOx requirement, ships sailing in a combined NECA / SECA area must either run on low sulphur fuel or run an exhaust gas cleaning process, i.e. a SOx scrubber system. The EGR system and the SCR high pres-

sure (HP) system will be able to run on high sulphur fuel, but in this case the exhaust gas system must be equipped with the SOx scrubber system. A SCR low pressure system (LP) can normally not be used for high Sulphur fuel on two stroke large bore slow speed diesel engines. When planning the Tier III installation, these conditions must be considered [4].

3.1 HP process

The SCR HP system can be used with fuels containing 3.5% sulphur. It consists of two main components, vaporizer/mixer, where a reducing agent is injected, and as the name implies, the agent will mix with exhaust gasses and vaporize before entering to the SCR reactor. The SCR reac-

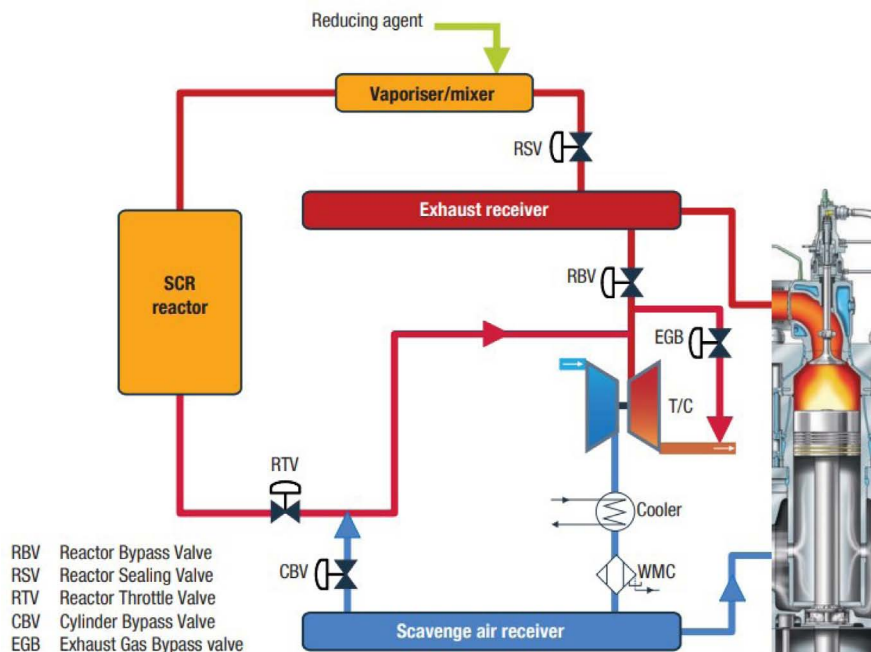

Figure 2 SCR HP system [3]

tor contains catalyst which is used to increase surface area in which the reaction takes place and to prevent ammonia slip. Catalyst can be made of various ceramic materials such as titanium oxide or base metal oxides like vanadium or tungsten [5].

When operating in Tier II mode, the SCR system can be by-passed by the reactor sealing valve (RSV) and the reactor throttle valve (RTV). The reactor bypass valve (RBV) is open and exhaust gas passes directly to the turbocharger. The system also includes an exhaust gas by-pass valve (EGB) to provide the engine with low load EGB tuning in Tier II. When operating in Tier III mode the SCR system will be started. The SCR line is opened by the valves, RSV and RTV, while the valve RBV will be closed. Even though the reactor is placed before the turbine, the exhaust gas temperature will still be too low at low loads [3]. There are several methods to operate SCR at low loads.

3.2 Low load method on HP system

During operation, when the engine load is 50% and below, the exhaust gasses do not satisfy the optimal temperature needed, so a “low load method” has to be developed [3].

To increase the temperature, a cylinder bypass from the scavenge air receiver to the turbine inlet is installed. The bypass flow is controlled by the cylinder bypass valve (CBV). When opening the bypass, the mass of air through the cylinders will be reduced without losing the scavenge air pressure, and accordingly, the exhaust gas temperature will increase. This system makes it possible to keep the temperatures above the required level. However, the cylinder bypass will increase the SFOC depending on the required temperature increase [3]. At very low loads, 15% or less, the reductant dispersion is stopped to prevent de-

posits forming. To prevent instabilities in HP system, an auxiliary blower will supply additional air to the system. The auxiliary blowers can supply air to the system up to 65% of maximum continuous ratio (MCR) [3]. Another method to increase the exhaust gas temperature on low loads is late injection (combustion).

3.3 LP process

Low pressure system can be installed only when using low sulphur fuels with 0.1% Sulphur or less, due to ammonium bisulfate (ABS – NH_4HSO_4) formation, which can occur in SCR reactor at low temperatures. When utilizing LP system, the SCR line is placed after T/C [3].

LP system consists of three major components: an SCR reactor, a mixer (AIG – Ammonia Injection Grid) and a decomposition unit (DCU). The DCU, which is placed in a gas line between the reactor outlet and mixer inlet, consists of a blower, a heater (burner) and a vaporizer. The reducing agent is injected into the vaporizer forming a mixture of ammonia vapor which is led to the mixer and finally to the SCR reactor, forced by the blower [3].

3.4 Limitations and preconditions

The main limiting factor of SCR system is the exhaust gas temperature. Due to high thermal efficiency of marine two stroke slow speed diesel engines, the exhaust gas temperature after the turbocharger(s) is around 230-260 °C, depending on the load, fuel quality and local conditions. Since the SCR optimal working temperature should be around 330-350 °C, when in high sulphur HFO operation (for exhaust gas pressure of 1.5 bar), the gas uptake has to be placed on turbine HP side. By such a placement the gas

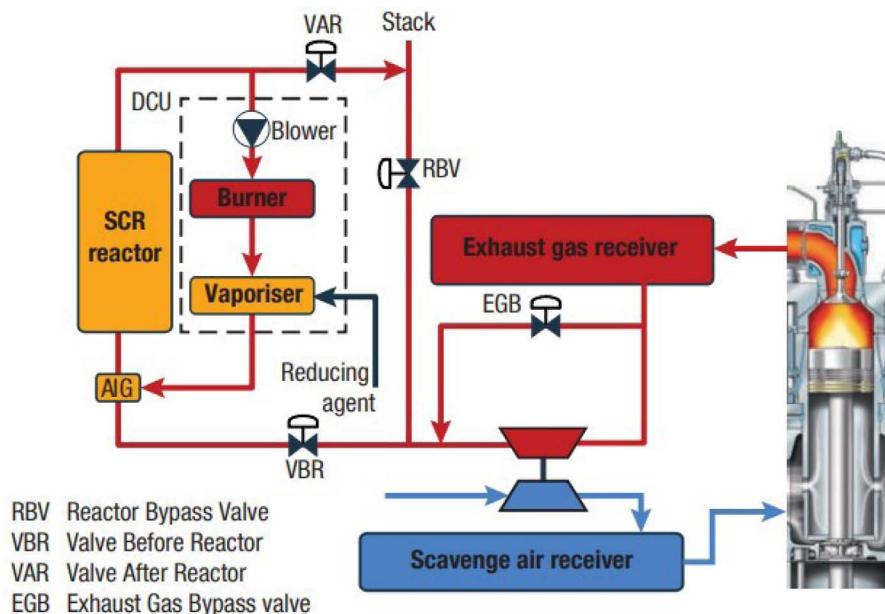

Figure 3 LP SCR system [3]



Figure 4 EGR and SCR HP and LP dimensional differences [3]

temperature increases between 50 °C and 175 °C [3]. With such a system T/C should be bigger and then becomes problem when operates in Tier II mode. At that mode exhaust gas with higher temperature cams to turbine. To limit T/C rpm at such a mode exhaust gas recirculation system (EGR) needs to be installed.

Also, as it can be noticed on Figure 4, there are huge differences in dimensions between those two systems, as well as between EGR. The systems placement into the engine room, because of their big dimensions, could be another limiting factor.

4 SCR parameter change and its effects on main engine parameters

In this chapter, the SCR parameters changed and analyzed their effects on main engine parameters. The main engine parameters which have been analyzed are exhaust gas temperature, scavenging air pressure and temperature and SFOC. Ammonia slip, as well as optimal value of urea dosage, were also investigated.

The analysis will be carried out on the engine room K-Sim simulator manufactured by Kongsberg. Engine room

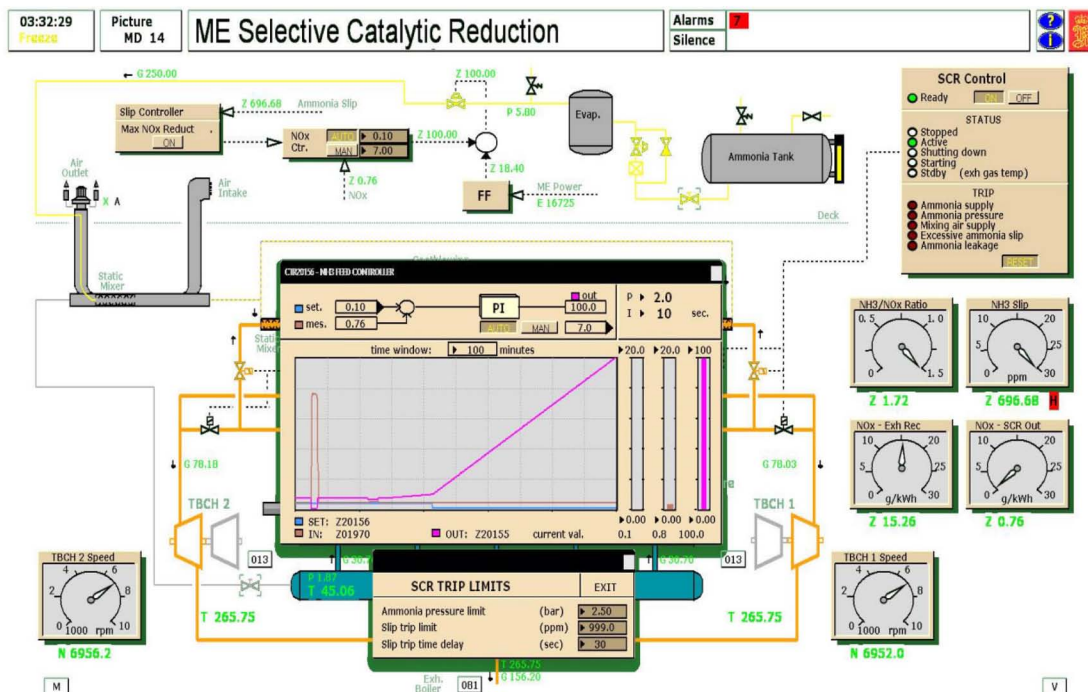

Figure 5 Max NOx reduction

model is MC90-V and initial condition will be set on full ahead, loaded ship, with steady weather condition and no sea currents (without external influences). After each change in the investigated parameters on SCR control panels, enough time will be left until the system stabilizes to analyze the changed parameters on ME.

In the Figure 5 is presented screenshot where it can be seen the initial analysis results, where the maximum reduction of NOx emission, on automatic operation, was examined. The SCR was operated on AUTO mode, but ammonia slip trip limit has been increased to maximum allowable limit of 999 ppm (normal – default value is 30 ppm) to avoid SCR shutting down. Maximum NOx emission that can be achieved was 0.76 g/kWh with the ammonia supply valve fully open (Z 100 – it shows percentage of valve opening) and the ME power at 16725 kW on 74 rpm (navigational full ahead engine speed). On the figure, proportional-integral (PI) controller can be seen, where input and output signals are presented. Magenta line presents slowly increasing output signal (during time) to the ammonia dosage valve up to 100% (fully) open since SCR NOx set point is set to minimum value of 0.10 g/kWh. Brown line clearly shows steady value of specific NOx emission which is 0.76 g/kWh and cannot go below that value regardless of ammonia dosage.

Ammonia slip is 696 ppm (Z 695.68), which is far beyond the permissible limit of 30 ppm (default setting). Therefore, further simulations were made to investigate and analyze the results obtained.

4.1 Maximum NOx reduction

To perform the research, the automatic slip control is turned off and ammonia pressure limit has been manually set to 5.7 bar. Slip trip limit has been set to the maximum

value (999 ppm), as well as the time delay to a value of 999 sec. The minimum ammonia pressure limit is 0.01 bar and maximum is 5.8 bar (normal – default pressure is 2.5 bar). Those SCR trip values were increased to maximum value to enable researching without constant tripping of SCR, as well as to reach the extreme limits which is very dangerous to implement on a real system. The NOx controller set point has been changed from 3 to 0.7 g/kWh. The values and maximum achievable NOx emission can be observed on the Fig. 6.

Looking at the chart (Fig. 6 and 7) it can be seen that no matter how much ammonia added after achieving 0.76 g/kWh, even with the supply valve fully open (maximum ammonia delivery), the end result remains the same and the ammonia slip value reaches its maximum value of 693.77 ppm. The value of 0.76 g/kWh is the lowest set point after which is no need to increase ammonia dosage.

Same applies for the ammonia flow rate (Fig. 7). Since the system cannot achieve the set point value of 0.7 g/kWh, the ammonia control valve opens fully trying to achieve the given set point. Set point value of 0.7 g/kWh has been set to investigate maximum value of ammonia flow and possibility to go below 0.76 g/kWh of NOx emission.

In stationary applications, the maximum permitted NH₃ slip is usually specified, with a typical specification at 5-10 ppm NH₃. A 10 ppm NH₃ limit is also applicable in some mobile SCR applications [2]. According to these data, on SCR slip controller, ammonia slip set point has been set to 10 ppm (maximum NOx reduction mode must be disconnected), and then the SCR NOx emission set point, on NOx controller, has been slightly adjusted to reach the value where ammonia slip is as close as possible to the value of 10 ppm of ammonia slip set point.

| NOx controller set point, g/kWh | ME NOx exh. content final, g/kWh | Ammonia slip value, ppm |
|---------------------------------|----------------------------------|-------------------------|
| 3 | 3 | 1.2 |
| 2 | 2 | 1.3 |
| 1 | 1 | 1.4 |
| 0.98 | 0.98 | 1.39 |
| 0.95 | 0.95 | 1.41 |
| 0.9 | 0.9 | 1.41 |
| 0.82 | 0.82 | 6.93 |
| 0.8 | 0.8 | 7.2 |
| 0.79 | 0.79 | 7.4 |
| 0.78 | 0.78 | 8.07 |
| 0.77 | 0.77 | 8.57 |
| 0.76 | 0.76 | 16.57 |
| 0.75 | 0.76 | 120.3 |
| 0.7 | 0.76 | 693.77 |

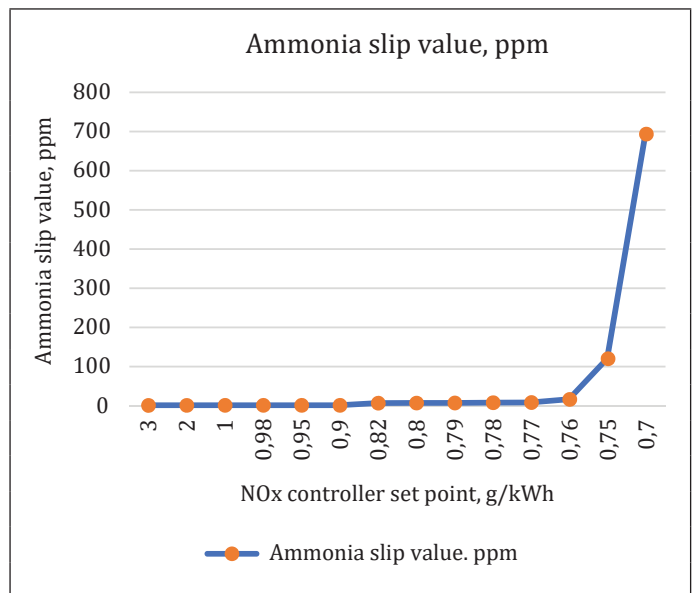

Figure 6 Ammonia slip value in relation to controller set point

| NOx controller set point, g/kWh | Ammonia flow, kg/h |
|---------------------------------|--------------------|
| 3 | 120.52 |
| 2.5 | 124.76 |
| 2 | 130.5 |
| 1.8 | 131.7 |
| 1.6 | 133.5 |
| 1.4 | 137.5 |
| 1.2 | 140.46 |
| 1 | 140.5 |
| 0.98 | 140.6 |
| 0.95 | 141.3 |
| 0.9 | 141.86 |
| 0.85 | 142.3 |
| 0.8 | 142.4 |
| 0.79 | 142.5 |
| 0.78 | 142.5 |
| 0.77 | 142.66 |
| 0.76 | 143.1 |
| 0.75 | 250 |

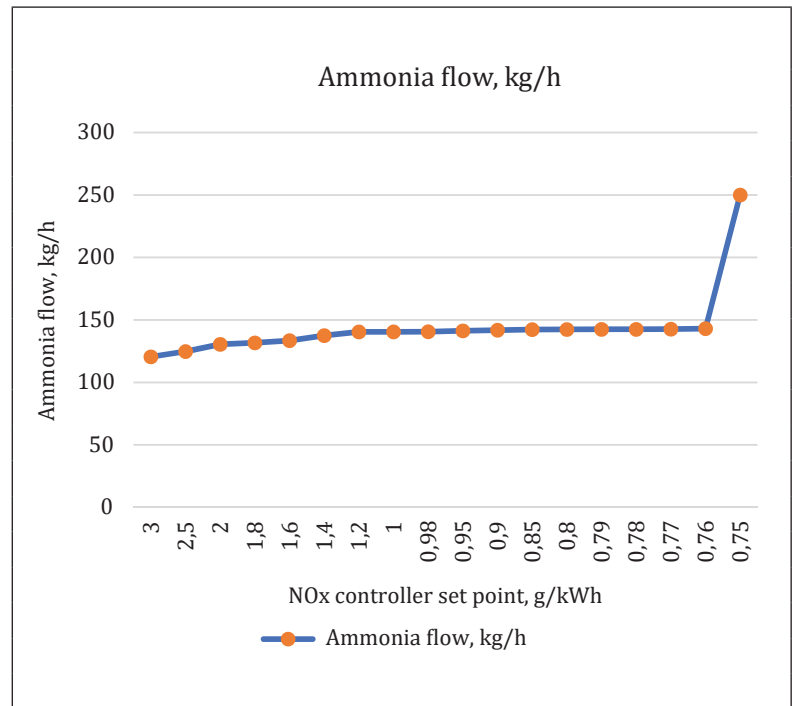

Figure 7 NOx controller set point in relation to ammonia flow

Source: Authors

From these tests it is concluded that the optimal NOx set point value that needs to be set to reach above mentioned values is between 0.7 and 0.8 g/kWh. When sailing in Tier III areas the limit value is 3.4 g/kWh, so the set point can be set up to that value and consequently the ammonia consumption will be lower.

4.2 SCR reactor impact on scavenging air pressure and temperatures after T/C on various engine speed

The principle of HP SCR operation system is explained in chapter 3. The scavenging air pressure and temperature on various engine speed were monitored and the results are shown in Figure 8.

Observing the SCR operation at different engine speed shows the scavenging air pressure drop but that should not affect the overall fuel economy too much. Anyway, it does raise the exhaust gas temperatures since there is a “rich” air-fuel mixture.

Turbo charger (T/C) temperature change with the SCR in operation, recorded after T/C, show an increase across all RPM range which is on par with the hypothesis above. The increase is necessary because the permissible reaction temperature is between 250-490 °C. Anything above or below will result in excessive ammonia slip and reactor shutdown to prevent clogging. The exhaust gas temperature before and after T/C increase because of additional

| ME rpm | Scavenging air pressure, bar (SCR off) | Scavenging air pressure, bar (SCR on) |
|--------|--|---------------------------------------|
| 74 | 2.05 | 1.88 |
| 70 | 1.8 | 1.5 |
| 65 | 1.37 | 1.17 |
| 60 | 1 | 0.82 |
| 55 | 1 | 0.65 |
| 50 | 0.53 | 0.47 |
| 45 | 0.45 | 0.41 |
| 40 | 0.4 | 0.29 |

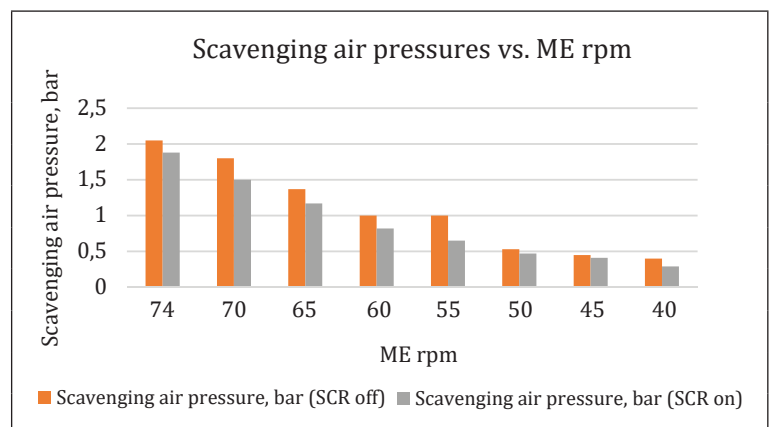

Figure 8 Scavenge air pressure change

Source: Authors

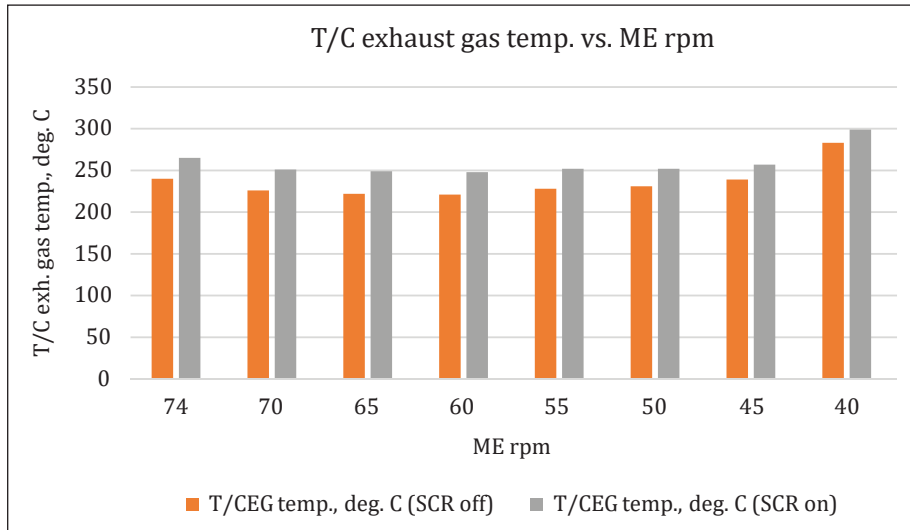

Figure 9 T/C temperature with SCR ON and OFF

Source: Authors

heat produced by injecting ammonia into SCR Reactor. Also on lower load, to maintain high exhaust gas temperatures for chemical reactions, variable injection timing system (mechanically or electronically VIT) could adjust time of injection to be later and therefore increase exhaust gas temperatures. For researched scenarios at lowest permissible load (rpm) where SCR can still be in operation, the start of fuel combustion is 8 degrees after TDC. If it weren't like this the exhaust gas temperature will be too low and SCR will be stopped much before. Maximum and minimum temperatures for SCR working process can be set on control panel (Fig. 10).

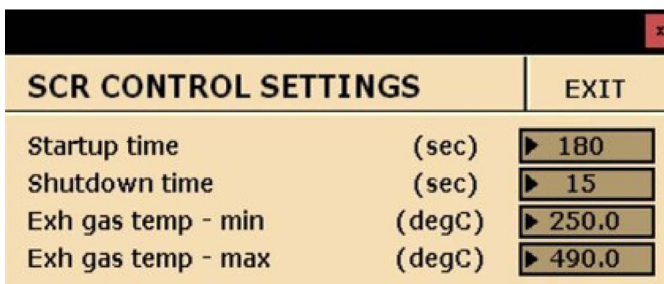

Figure 10 Maximum and minimum permissible temperature for SCR working process

Source: Authors

Setting the value below will result that reactor start with insufficient exhaust gas temperature and therefore ammonia slip will occur. Same applies if the temperature is too high, at 400 °C a sharp decrease in DeNOx activity occurred and at 480 °C a negative DeNOx activity occurred as well as increased ammonia slip [6]. On the other hand, the temperature must not be too high as this will result in

an increased SO₃ formation in the catalyst. SO₃ subsequently reacts with water creating sulphuric acid, which appears as an undesired white aerosol plume. Another undesired reaction which also limits the upper temperature for SCR operation is the oxidation of NH₃ as the exhaust gas temperature approaches 500 °C, i.e. more NH₃ is needed. Additionally, the catalyst material starts to sinter at temperatures above 500-550 °C [3].

4.3 SCR effects on SFOC

The focus of next test was to check if there is an increase in SFOC due to a slight drop in scavenging air pressure or late injection. The test is being done on different engine speed and each test result was recorded after 1 hour of operation (Fig. 11).

From Figure 11 it can be seen that there is change in SFOC on different RPMs. A slight increase is caused due to above mentioned change in air-fuel mixture, specifically a drop in air pressure which is entering the cylinders. Also, efficiency drop is caused by VIT system which move injection timing far after TDC (in this case 8° crank angle (CA) after TDC – at 40 and 45 ME rpm). Also, the duration of injection is increased (from 7 to 7,3 °CA), which directly influence to exhaust gas temperatures increasing which is at 45 rpm around 280°C (reaction temperature into SCR is 300 °C) and at 40 rpm around 342 °C (reaction temperature into SCR is 340 °C). The exhaust gas pressure is 1.55 bar at 74 rpm and 0.2 bar at 40 rpm. The biggest increase in SFOC is around 55 to 60 and 40 to 45 ME rpm. The reaction temperature increasing is caused by late fuel oil injection, by burning of ammonia and due to air supply from scavenging air receiver.

Figure 12 shows that NOx emission during all engine speed, when SCR in operation, remain almost the same

| ME rpm | SFOC increase when SCR in operation, % |
|--------|--|
| 74 | 0.5 |
| 70 | 0.6 |
| 65 | 0.5 |
| 60 | 1.1 |
| 55 | 1.5 |
| 50 | 0.0 |
| 45 | 0.8 |
| 40 | 1.7 |

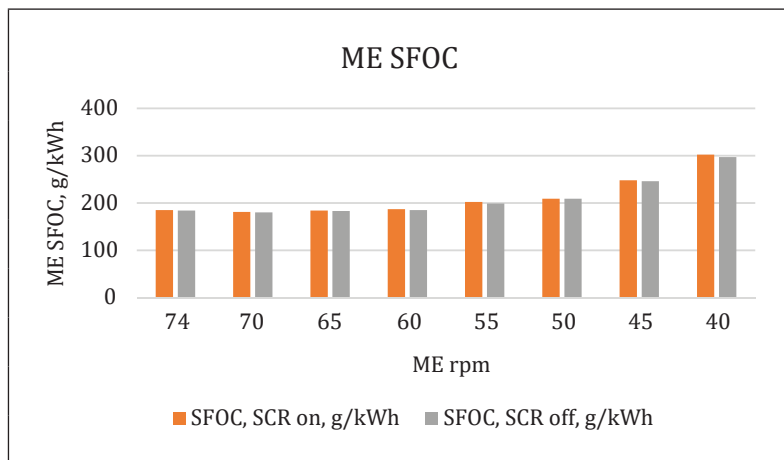

Figure 11 Difference in SFOC during SCR operation

Source: Authors

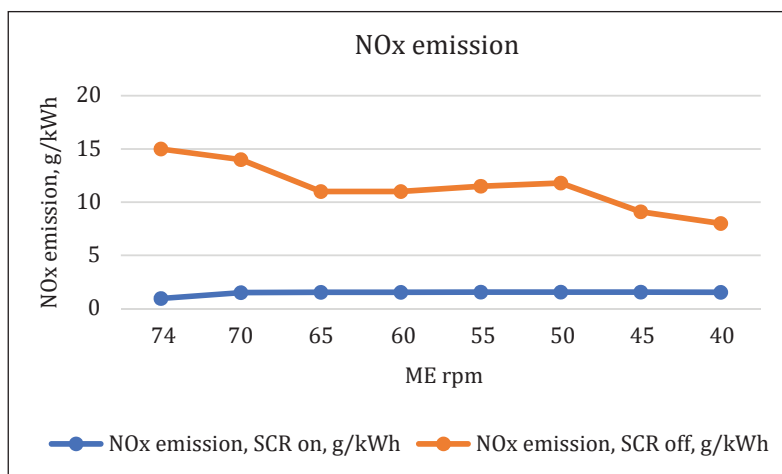

Figure 12 NOx emission during the examined process

Source: Authors

since controller holds the NOx emission limit around 1.5 g/kwh. When SCR is stopped, NOx emission depends on total fuel oil consumption (g/h) and, of course, on reaction temperature.

5 Conclusion

Taking into account all systems used to reduce NOx emissions, SCR reactors are by far the best solution. It does not require much modification to the main engine when comparing it to EGR, doesn't require complicated control systems and is easy to maintain as there is no waste products regarding the reaction. Not to mention that most of the systems above, (except EGR and use of LNG as a fuel), are not enough to comply with Tier III regulations of 3.4 g/kWh, and are primarily used in combination with either EGR or SCR. The only issue with the

system is the aforementioned ammonia slip and the fact that the ammonia is combustible.

By changing the parameters of ammonia dosage, it can be seen that the minimum NOx emission which can be achieved is 0.76 g/kWh and optimal value depends of urea price and engine load. Since on lower engine loads the SCR reactor must be stopped or injection timing should be very late, to remain higher exhaust gas temperatures needed for chemical reaction, optimal value of NOx set point vary a lot and it is not investigated in this paper. It can be concluded that the optimal way is to set it on the upper allowed NOx emission limit (3.4 g/kWh), because then it is the least urea consumption.

When SCR is in operation, at 74 RPM (full ahead) an increase of 0.5% in SFOC, a decrease of 8.3% in scavenge air pressure and an increase of 10.4% in T/C temperatures can be observed. This changes do not affect to normal en-

gine operation. Such a system has been tested and installed on multiple ships and from the results of the above analysis, it can be seen that has negligible impact on SFOC and other important ME parameters, except on lower engine speed where ME efficiency has been reduced.

Funding: The research presented in the manuscript did not receive any external funding.

Author Contributions: Filip Rumac: Chapter 1, 2 and 3; Darko Glujić: Chapter 4 – KS Simulator results and MATLAB results comparison; Dean Bernečić: Chapter 4 – Simulation research on KS Simulator and simulation results analysis.

References

- [1] [http://www.imo.org/en/ourwork/environment/pollutionprevention/airpollution/pages/nitrogen-oxides-\(nox\)-%E2%80%93regulation-13.aspx](http://www.imo.org/en/ourwork/environment/pollutionprevention/airpollution/pages/nitrogen-oxides-(nox)-%E2%80%93regulation-13.aspx)
- [2] https://dieselnet.com/tech/cat_scr.php
- [3] https://man-es.com/applications/projectguides/2stroke/content/special_pg/PG_7020-0145.pdf
- [4] <https://www.scirp.org/journal/paperinformation.aspx?paperid=93989>
- [5] https://en.wikipedia.org/wiki/Selective_catalytic_reduction
- [6] https://backend.orbit.dtu.dk/ws/portalfiles/portal/161974766/PhD_thesis_Steen_Riis_Christensen.pdf
- [7] https://www.matec-conferences.org/articles/mateconf/pdf/2015/07/mateconf_acmme2015_03002.pdf
- [8] Kongsberg engine room simulator instruction manual – Model MC90V ERS L11 5L90MC
- [9] Lenka S. Chladova, Evaluation of Selective Catalytic Reduction for Marine Two-Stroke Diesel Engines, Master of Science degree Thesis, Aalborg University, 2010.